

Xpelair WH30, WH60 & WHP30

Commercial wall heaters



The Range

The Xpelair WH range of space wall heaters are tough, compact and have stood the test of time to remain market leaders. The WHP30 is suitable for commercial applications such as shops, offices, domestic workshops and conservatories. WH30 and WH60 models provide robust and rugged heating units suitable for the most demanding industrial environments.

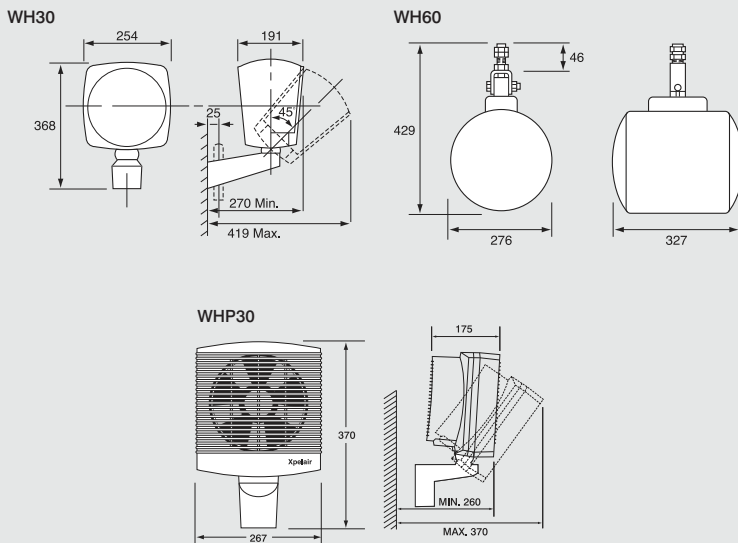

Key Features

- 3 models are available (WHP30 (Commercial), & WH30 - WH60 (Industrial))
- Complete with mounting brackets
- Incorporates thermal safety cut-out
- WHP30 & WH30 controlled by HC301 On/Off and thermostatic controller

Models

XPEWH30

3kW industrial fan heater | Compact wall-hung design
Heavy duty steel casing with die cast aluminium guards
Spiral wound Nichrome wire element | Metal wall bracket
Multi directional positioning - 180° horizontal swivel and 45° vertical tilt then locked in position | Wall bracket cover
Double safety feature of thermal cut-out with auto reset and one shot fusible link | Single phase product | For cool air circulation facility and thermostatic heating control use HC301 Controller (supplied separately)

XPEWH60

features over the WH30

6kW industrial fan heater | Wall or ceiling mounting with multidirectional positioning - 180° horizontal swivel and 45° vertical tilt then locked in position | Suitable for single and three phase supplies | Operated by remote switch (supplied separately)

XPEWHP30

3kW commercial fan heater | Fan heater complete with HC301 thermostatic controller | Compact wall-hung design | Flame retardant polycarbonate / glass filled nylon casing | Spiral wound Nichrome wire element | Grey wall bracket | Multi-directional positioning - 180° horizontal swivel and 45° vertical tilt then locked in position | Double insulated with two thermal cut-outs | Finished in a white and grey casing | Single phase product | For cool air circulation facility and thermostatic heating control use HC301 Controller (included)

Controllers - pages 28 and 29

HC301 use with WH30, WHP30

Product Selector

	WH30	WH60	WHP30
Reference number	98392AC	00147AC	89999AW
Remote switch (supplied separately)	■	■	
Electrical power (kW)	3	6	3
Phase	1	1 or 3	1
Air delivery (m ³ /h)	274	311	300
Air delivery (l/s)	76	86	83
Temperature increase (°C)	26	45	30
Weight (kg)	5	6.5	2.9
Guarantee (years)	2	2	1